

# DEMР-AC3(MID)

## 安装使用说明书 V1.0

Installation and operation instruction V1.0



## 申明

版权所有，未经本公司之书面许可，此手册中任何段落、章节内容均不得摘抄、拷贝或以任何形式复制、传播，否则一切后果由违者自负。

本公司保留一切法律权利。

The copyright is the property of DEGSON. Any information in any paragraph or section cannot be extracted, copied or otherwise reproduced or propagated. Otherwise offenders shall take all consequences.

All rights are reserved.

本公司保留对本手册所描述之产品规格进行修改的权利，恕不另行通知。订货前，请垂询当地代理商以获悉本产品的**当前**规格。

DEGSON reserves the right to modify the product specifications herein without notification. Please consult the local agent about the latest specifications before placing a purchase order.

## 说明书修订记录

日期 Date	旧版本 Old	新版本 New	修改内容 Change
2022.05.17		T1.0	1.第一次编写 1.First version
2022.08.19	T1.0	T1.1	2.增加直接接入型号 2.Add direct access model
2023.02.08	T1.1	T1.2	3.增加型号寄存器 3.Add Device model register
2023.12.21	T1.2	T1.3	4.增加部分细节描述 4.Added some detailed descriptions
2024.03.21	T1.3	T1.4	5. 增加一个电流规格 6. 增加数据单位描述 7. 替换电表尺寸图 5. Add a current specification 6. Add some descriptions of data units 7. Edit the size description image
2024.09.24	T1.4	T1.5	8. 修改电能精度等级说明 9. 修改二次接入力矩值 8.Modify the description of the energy accuracy class 9.Amend the torque of connect via CT
2025.04.15	T1.5	T1.6	10. 修改接线图端子标识 11. 修改说明书地址表内的一些描述错误 10.Modify wiring diagram terminal identification 11.Modify address table section description error

# 目 录

## Catalog

1 概述 <b>General</b> .....	- 1 -
2 型号说明 <b>Type description</b> .....	- 1 -
3 功能列表 <b>Function description</b> .....	- 1 -
4 技术参数 <b>Technical parameter</b> .....	- 2 -
5 外形尺寸 <b>Outline</b> .....	- 3 -
6 接线与安装 <b>Wiring and installing</b> .....	- 4 -
7 主要功能特点 <b>Function description</b> .....	- 6 -
8 操作与显示 <b>Operation and display</b> .....	- 7 -
9 通信说明 <b>Communication description</b> .....	- 14 -

# 1 概述 General

DEMUR-AC3 导轨式多功能电能表，是主要针对电力系统，工矿企业，公用设施的电能统计、管理需求而设计的一款智能仪表，产品具有精度高、体积小、安装方便等优点。集成常见电力参数测量及电能计量及考核管理，提供上 48 月的各类电能数据统计。具有 2~31 次分次谐波与总谐波含量检测。带有 RS485 通信接口，可选用 MODBUS-RTU 协议。该电力仪表可广泛应用于各种控制系统，SCADA 系统和能源管理系统中。产品符合 IEC62053-21 认证。

DEMUR-AC3 is a smart meter designed for power supply system, industrial and mining enterprises and utilities to calculate the electricity consumption and manage the electric demand. It features the high precision, small size and simple installation. It integrates the measurement of all electrical parameters with the comprehensive electricity metering and management provides various data on previous 48 months, checks the 2nd-32st subharmonics and the total harmonic content, realizes the remote communication and the remote control with switching input and relay output and boasts the alarm output. It is fitted with RS485 communication port and adapted to MODBUS-RTU. DEMUR-AC3 can be used in all kinds of control systems, SCADA systems and energy management systems. The meter meet the related technical requirements of electronic meter in the IEC62053-21standards.

# 2 型号说明 Type description

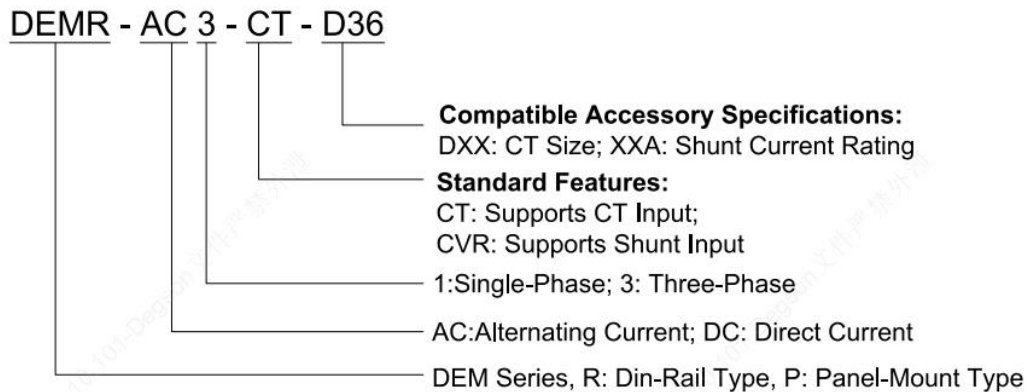

# 3 功能列表 Function description

表 1 功能说明列表  
 Table 1 Function description list

功能 Function	功能说明 Function description	功能配置 Function provide
电能计量 Measurement of energy	有功电能计量（正、反向） Active kWh (positive and negative)	■
	无功电能计量（正、反向） Reactive kvarh (positive and negative)	■
	A、B、C 分相正向有功电能 A, B, C split phase positive active energy	■
电量测量	U、I	■

Measurement of electrical parameters	P、Q、S、PF、F	■
谐波测量 Measurement of harmonics	2~31 次谐波电压电流 2~31 <sup>ST</sup> Voltage and current harmonic	■
LCD 显示 LCD Display	12 位段式 LCD 显示、背光显示 12 bits section LCD display, background light	■
按键编程 Key programming	3 按键可编程通信、变比等参数 3 keys to communication and set parameters	■
脉冲输出 Pulse output	有功脉冲输出 Active pulse output	■
复费率及 附带功能 Multi-tariff and functions	日期、时间 Date, time	<input type="checkbox"/>
	最大需量及发生时间 Max demanded kWh and time happened	<input type="checkbox"/>
	上 48 月、上 90 日历史冻结数据 Frozen data on last 48 months, last 90days	<input type="checkbox"/>
	支持 4 个时区、4 个时段表、 14 个日时段、4 个费率 Adapt 4 time zones, 4 time interval lists, 14 time interval by day and 4 tariff rates	<input type="checkbox"/>
通讯 Communication	RS485 接口, 支持 Modbus Communication interface: RS485, Communication protocol: MODBUS-RTU	■

## 4 技术参数 Technical parameter

表 2 技术参数说明

Table 2 technical parameter descriptions

项目 project		性能参数 performance parameter	
规格 Specification		三相四线 3 phase 4 wires	
测量 Measurement	电压 Voltage	参比电压 Reference voltage	3×230/400V
		电压范围 Voltage range	3×57.7/100V~3×276/478V
		功耗 Consumption	<10VA(单相)(Single phase)
		阻抗 Impedance	>2MΩ
		精度等级 Accuracy class	误差±0.2% (Error±0.2%)
	电流 Current	输入电流 Input current	0.01-1(6)A (二次接入 Secondary access model) 0.1-10(80)A(直接接入 Direct access model)

		0.1-10(100)A(直接接入 Direct access model)
	功耗 Consumption	<1VA(单路额定电流) (Single phase rated current)
	精度等级 Accuracy class	误差±0.2% (Error±0.2%)
	功率 Power	有功、无功、视在功率, 误差±0.5% Active, reactive, apparent power, error±0.5%
	电网频率 Frequency	45~65Hz, 误差±0.2% (Error±0.2%)
计量 Measurement	电能 Energy	准确度等级 Accuracy class 0.01-1(6)A, 0.1-10(80)A: C级 ClassC 0.1-10(100)A: B级 ClassB
	时钟 Clock	≤0.5s/d
数字 信号 Digit -signal	电量脉冲输出 Energy pulse output	1路有功光耦输出 One active photocoupler output
脉冲 pulse	脉冲宽度 Width of pulse	80±20ms
	脉冲常数 Pulse constant	直接接入: 400imp/kWh 二次接入: 10000imp/kWh Direct access model, 400imp/kWh Secondary access model, 10000imp/kWh
通信 Communi- cation	接口与通信规约 Interface and communication	RS485: Modbus RTU
	通信地址范围 Range of communication address	Modbus RTU:1~247;
	波特率 Baud rate	1200bps~38400bps
环境 Environ- ment	工作环境 work environment	室内(如需在户外使用, 请为电表配备防水防尘表箱) Indoor (If it needs to be installed outdoors, please add a dustproof and waterproof shell )
	工作温度 Relative temperature	-25°C to +55°C (二次接入 Secondary access model) -40°C to +70°C(直接接入 Direct access model)
	相对湿度 Relative humidity	≤95% (无凝露) (No condensation)
	防护等级 IP Rating	IP51 必须安装在合适的 IP 防护等级外壳中 Must be installed in a suitable IP rated enclosure

## 5 外形尺寸 Dimension drawings



图 1 DEMR-AC3-CT 互感器接入  
Fig1 DEMR-AC3-CT connect via CT



图 2 DEMR-AC3 直接接入  
Fig 2 DEMR-AC3 direct connect

注：直接接入的接线力矩应该在 3-4N·m，经互感器接入的接线力矩应该在 0.5N·m。

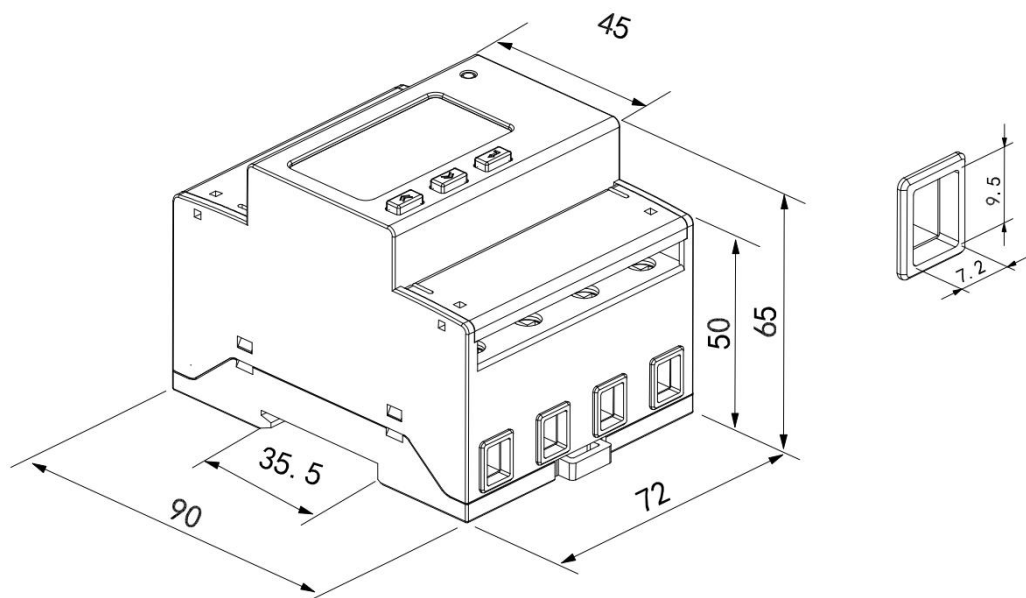
Note: The torque of direct connect should be 3-4N·m, and the torque of connect via CT should be 0.5N·m.

## 6 接线与安装 Wiring and installing

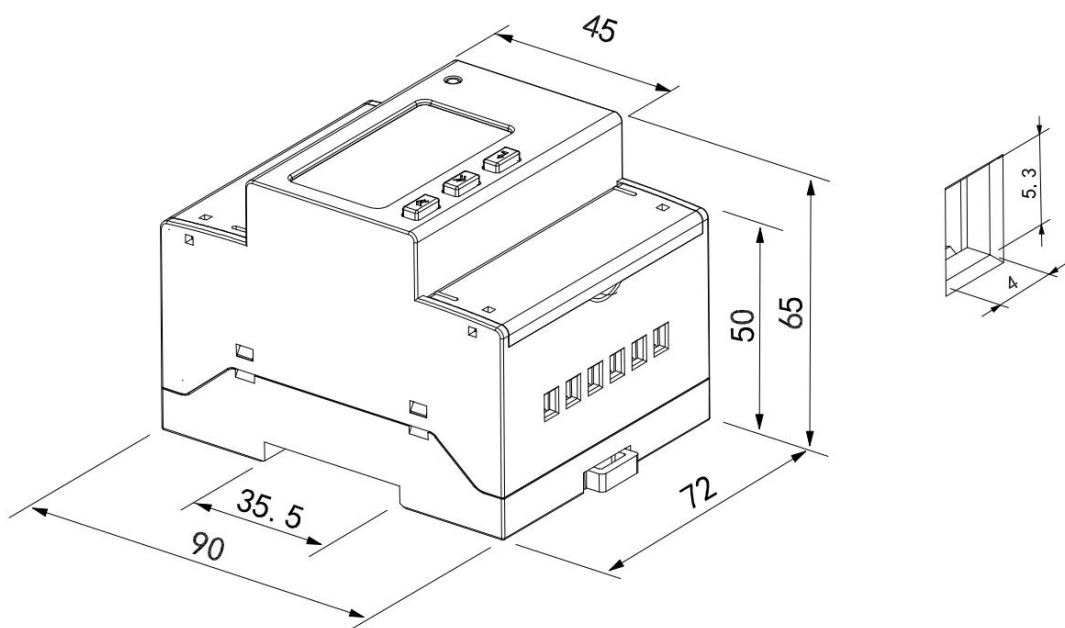
### 6.1 电压电流接线示意图 Wiring sample of voltage and current



图3 三相四线经互感器接入

Fig2 Three phase four lines connect via CT

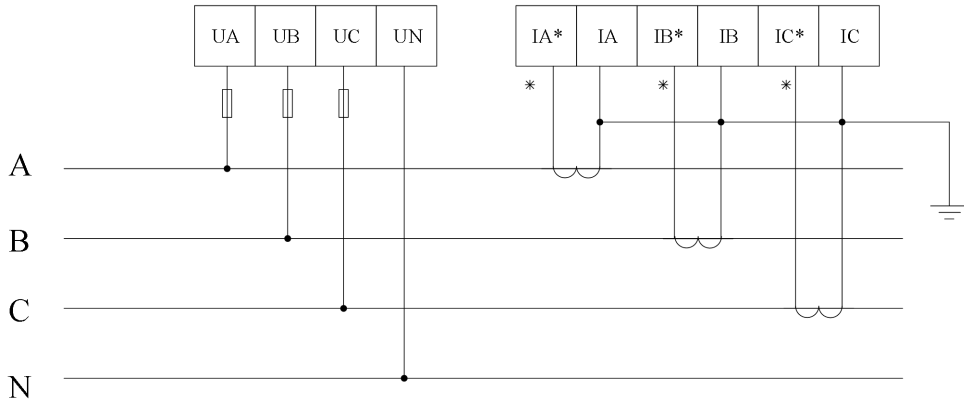

图4 三相三线经互感器接入

Fig 4 Three phase three lines connect via CT

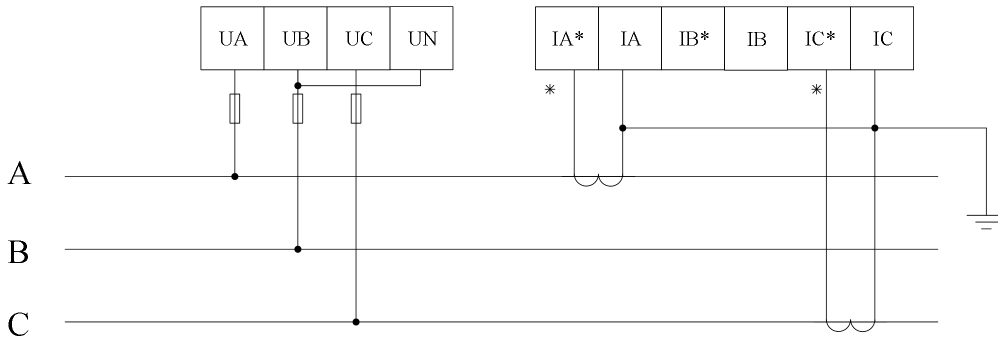

图5 三相四线直接接入

Fig 5 Three phase four lines direct connect

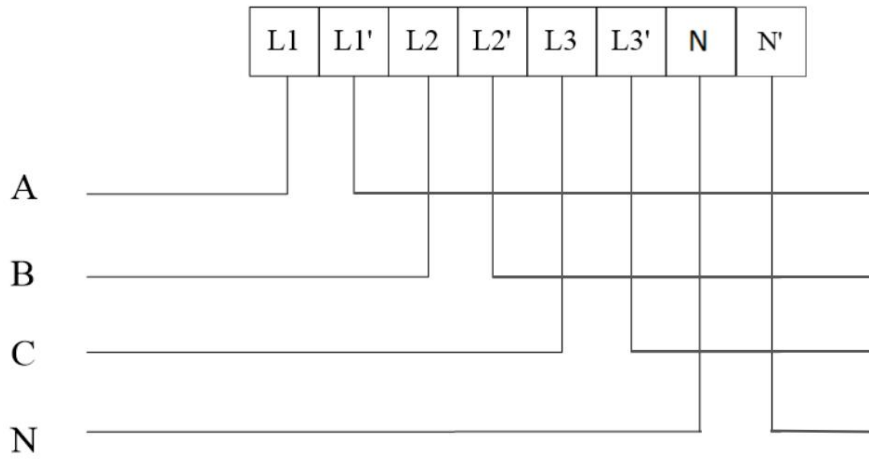

图 6 三相三相直接接入  
Fig 6 Three phase three lines direct connect

注:

1. 标准 35mm 导轨条安装 (无需维护、修理、调整);
2. 根据 2014/32/EU 指令, 仪表拟安装在机械环境 “M1” 中, 冲击和振动的重要性较低;
3. 根据 2014/32/EU 指令, 仪表拟安装在电磁环境 “E2” 中。

Note:

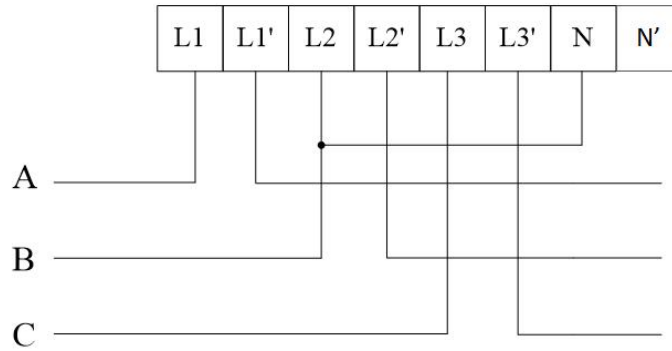
1. Installation of standard 35mm guide rail ( No maintenance, repair or adjustment intended )
2. The meter is intended to be installed in a Mechanical Environment ‘M1’, with Shock and Vibrations of low significance, as per 2014/32/EU Directive.
3. The meter is intended to be installed in Electromagnetic Environment ‘E2’, as per 2014/32/EU Directive.

## 6.2 通讯、脉冲端子接线示意图

### 6.2 Wiring diagram of communication and pulse terminals



图 7 通讯、脉冲接线

Fig 7 Communication, pulse connection

## 7 主要功能特点 Function description

### 7.1 测量功能 Measurement

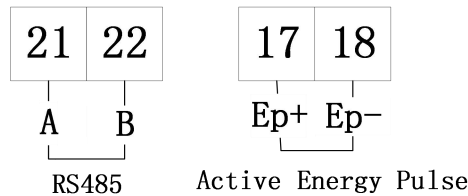
能测量全电力参数,包括 U、I、P、Q、S、PF、F、2-31 次分次谐波及总谐波含量。

It can measure the electrical parameter, include U, I, P, Q, S, PF, F, 2nd-31st harmonics and total harmonic content.

如:  $U = 220.1V$ ,  $f = 49.98Hz$ ,  $I = 1.99A$ ,  $P = 0.439kW$

Such as,  $U = 220.1V$ ,  $f = 49.98Hz$ ,  $I = 1.99A$ ,  $P = 0.439kW$ .

### 7.2 计量功能 Calculating

能计量当前组合有功电能, 正向有功电能, 反向有功电能, 正向无功电能, 反向无功电能。

Can measure the total active energy, forward active energy, reversing active energy, forward reactive energy, reversing reactive energy.

### 7.3 分时功能 Timing

两套时段表，一年可以分为 4 个时区，每套时段表可设 14 个日时段，4 个费率(F1、F2、F3、F4 即尖峰平谷)。

There are four time tables, the year can be divided into four time zones, and every table have fourteen daily time periods and four rates can be set.

### 7.4 需量功能 Demand

有关需量的相关概念如下：

The description about demand:

表 3 需量概念表

Table 3 Demand description list

需 量 Demand	需量周期内测得的平均功率叫需量 The average power in the demand cycle.
最大需量 Maximum demand	在指定的时间区内需量的最大值叫最大需量 The maximum value of demand in a period of time.
滑差时间 Slip time	从任意时刻起，按小于需量周期的时间递推测量需量的方法，所测得的需量叫滑差式需量。递推时间叫滑差时间。 The method of measuring the demand from any point in time by a recurrence of time less than the period of the demand is called sliding demand. The recurrence time is called the slip time.
需量周期 Demand cycle	连续测量平均功率的相等的时间间隔，也叫窗口时间。 An equal interval of time between successive measurements of average power, also called window time.

缺省需量周期为 15 分钟，滑差时间为 1 分钟，两者均不可修改。

能测量 4 种最大需量即正向有功、反向有功、感性无功、容性无功最大需量以及最大需量发生的时间。

The default demand cycle is 15 minutes, slip time is 1 minute.

The meter can measure 4 kinds of maximum demand, forward active, reversing active, inductance reactive, capacitance reactive maximum demand and the time of occurrence.

### 7.5 历史数据统计功能 History data statistics

能统计上 48 月的历史电能（各费率电能）和上 90 日的历史电能（各费率电能）。

The meter can record last 48 months and last 90 days history energy in each tariff.

## 8 操作与显示 Operation and display

### 8.1 按键功能说明 Key function description

表 4 按键功能说明

Table 4 Key's function description

按键图标 icon	按键名称 Name	按键功能 Function
	电压电流类 向上键 Voltage and current, up	查看界面中查看电压电流 编程界面中上翻及闪烁移位 Check the voltage and current Leftward and change flash in programming menu







	<p>功率类 向下键 Power, down</p>	<p>查看界面中查看功率 编程界面中下翻及修改闪烁位 Check the power Rightward and change the value on flash</p>
	<p>电能类 编程确定键 Energy, enter</p>	<p>查看界面中查看电能 长按 3S 进入/退出菜单 编程界面中短按确定保存设置 Check the energy In/out programming menu Save changes</p>

## 8.2 显示界面 Display menu

上电后显示总有功电能。可通过三类查看键实现翻页显示。各类显示界面顺序说明如下：

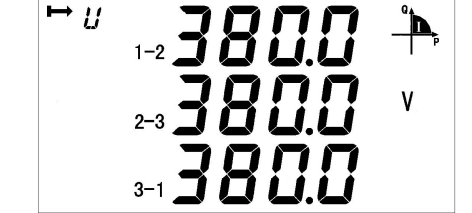
The meter will show the forward active energy after powering. The customers can change the information showing by pressing the keys. The menu description is listed as below.

表 5 显示界面说明  
Table 5 display descriptions

		
	<p>相电压 Three-phase voltage</p>	<p>线电压 Three phase line voltage</p>
		
	<p>电流 Three-phase Current</p>	<p>频率 Frequency</p>
		
	<p>三相电压谐波含量 Harmonic content of three phase Voltage</p>	<p>三相电流谐波含量 Harmonic content of three phase Current</p>

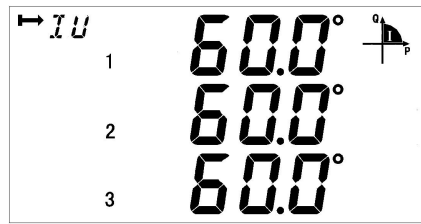

相位角

Phase angle

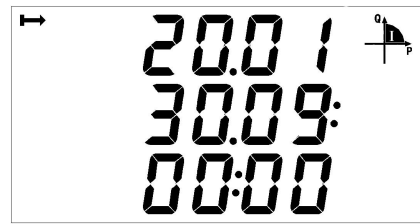

时间

Time



校验位、波特率、表地址

Check bit, baud rate, meter address,

软件版本号、软件唯一识别码、全显检测；

And software version number, Software unique identifier, full display detection.

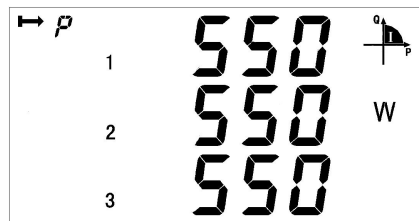

三相有功功率

Three phase active power



总有功功率

Total active power

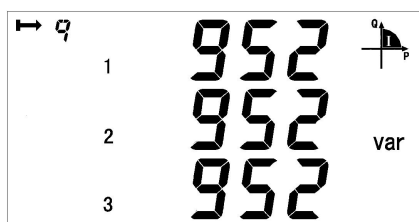

三相无功功率

Three phase reactive power

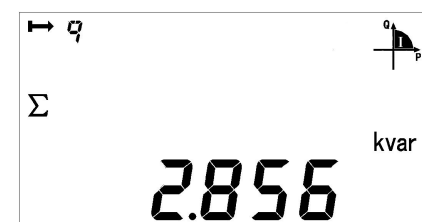

总无功功率



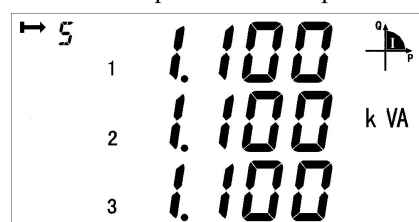







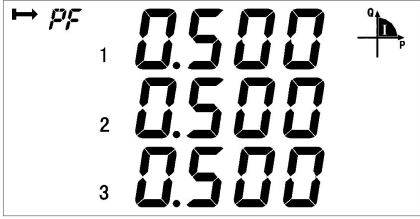

Total reactive power



三相视在功率



总视在功率

	<p>Three phase apparent power</p>  <p>三相功率因数</p>	<p>Total apparent power</p>  <p>总功率因数</p>
	<p>T3 represents the normal period, ① represents the first time table</p>  <p>当前组合有功总电能 Current total active energy</p>	 <p>当前组合有功尖电能 Current spike active energy</p>
	 <p>当前组合有功峰电能 Current peak active energy</p>	 <p>当前组合有功平电能 Current flat active energy</p>
	 <p>当前组合有功谷电能 Current valley active energy</p>	 <p>当前正向有功总电能 Current forward active total energy</p>
	 <p>当前反向有功总电能 Current reversing active total energy</p>	 <p>当前组合无功总电能 Current total reactive energy</p>



当前组合无功尖电能

Current reactive spike energy



当前组合无功峰电能

Current reactive peak energy

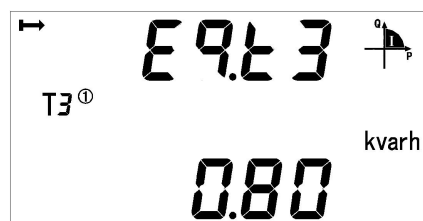

当前组合无功平电能

Current reactive flat energy

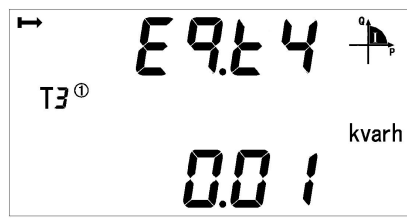

当前组合无功谷电能

Current reactive valley energy

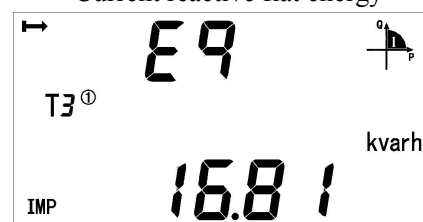

当前正向无功总电能

Current forward reactive total energy

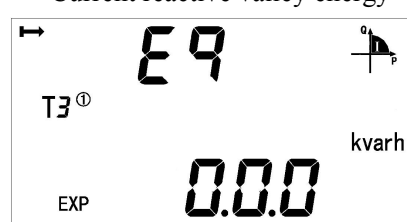

当前反向无功总电能

Current reversing reactive total energy

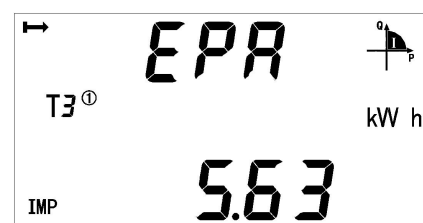

当前正向 A 相有功总电能

Current forward active energy  
on A phase



当前正向 B 相有功总电能

Current forward active energy  
on B phase



当前正向 C 相有功总电能

Current forward active energy on C phase

说明:

1、以上所列为 DEMR-AC3 三相四线带有复费率功能的仪表所有显示界面名称，三个按键可切换不同类型的显示内容，切换顺序如上所述；

2、对于 DEMR-AC3 不带有复费率功能的仪表，不显示日期、时间及各类的分时电能（即尖、峰、平、谷四种费率时段的电能）；

3、对于 DEMR-AC3 不带有复费率功能的仪表，不显示日期、时间及各类的分时电能（即尖、峰、平、谷四种费率时段的电能）；

4、屏幕左上角箭头代表 DIR 设置，从左到右表示 DIR 设置为 0；如果箭头从右到左，则表示 DIR 设置为 1；

5、屏幕左下角‘IMP’表示当前显示是正向的数据，‘EXP’表示当前显示的是反向的数据。

Note,

1. All the display menus above are in the model of DEMR-AC3 three phases four lines with multi-tariff rate function and can be changed by the keys.





2. There will not be power or power factor on each phase and will only show total power and power factor (active, reactive, apparent) under the three phase three lines.





3. There will not be date, time, maximum demand and energy by time without the function of multi-tariff rate.

4. The arrow in the upper left corner of the screen represent the DIR settings, from left to right means that DIR is set to 0; if the arrow is from right to left, it indicates that DIR is set to 1.

5. ‘IMP’ in the lower left corner of the screen means forward, and ‘EXP’ means reverse.

### 8.3 编程界面 Key Menu

在测量显示菜单中的任一显示项下，长按  可进入“PASS”界面，输入密码后再按 ，若密码输入错误，则返回“0000”可重新输入；若密码输入正确，则可进行参数设置。设置完成后长按  进入“SAVE”界面，“YES”下按  则保存后退出，“no”下按  则不保存直接退出。

Keep press  at any main menu and get in “PASS” interface, and then press  show “0000”, and enter the code. If you enter a wrong code, it will show “fail” and back to main menu; and if you enter a right code, you can set the parameter. After setting the parameter and keep press , it will show “save” and save the change by pressing  in “yes” interface and quit without save by pressing  in “no” interface.

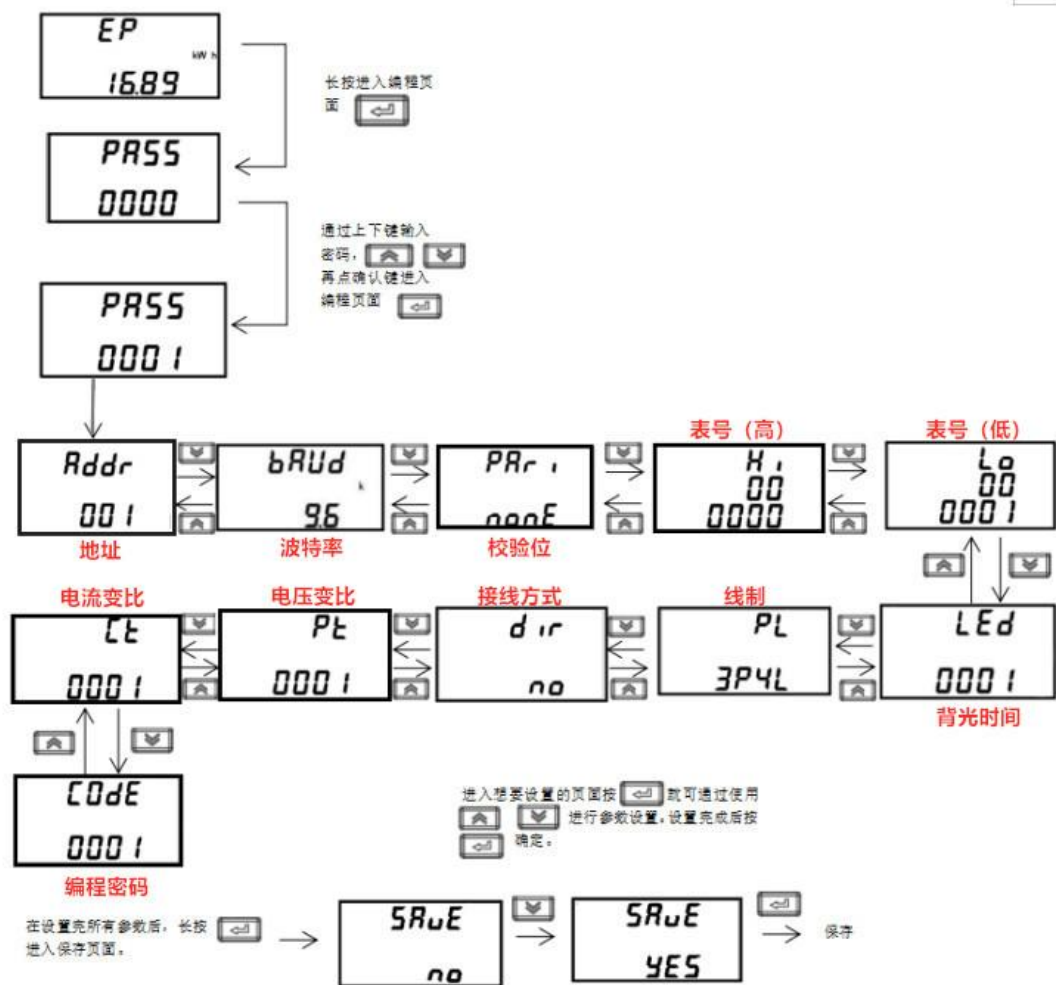

## 8.4 可设置数据项 Data settings

表 6 设置菜单说明

Table 6 setting menu description

序号 Num	二级菜单 Second menu		
	符号 Symbol	含义 Mean	范围 Range
1	ADDR	通讯地址设置 Communicate's ADDR settings	1-247
2	Baud	波特率选择 Baud choose	1200、2400、4800、9600、19200、38400
3	Pari	校验选择 Parity choose	None、Odd、Even
4	LED	背光时间设置 Backlight time	1-255 分钟，0 为常亮 1-255minutes, 0 means always on
5	PL	网络选择 Wiring sample	3P4L:三相四线 3 phase 4 wires 3P3L:三相三线 3 phase 3 wires
6	DIR	电流方向 direction of current	no-正向 yes-反向

8	EF-E	复费率开关 time-sharing measurement function	EF-开, E-关 EF-Function on E-Function off
9	Pt	电压变比 Voltage transformer settings	1-9999
10	Ct	电流变比 Current transformer settings	1-9999
11	CoDE	密码设置 Code settings	1-9999
12	PHAS	相位角计算方式 Phase angle calculation method	No-各相电流与各相电压 Yes-各相电流与 A 相电压 No-Angle between each current and each voltage Yes-Angle between three-phase current and phase a voltage
13	nost	起动功率屏蔽值 Starting power shield	屏蔽范围: 0.1-2.0%(*UnIn) Shielding range, 0.1-2.0%(*UnIn)

## 9 通信说明 Communication description

仪表 RS485 通信接口支持 MODBUS-RTU 通信协议, 通信口波特率可在 1200bps、2400 bps、4800 bps、9600bps、19200bps 和 38400 bps 之间设置, 校验位默认为无校验。

仪表的 RS485 通信口要求使用屏蔽双绞线连接, 布线时要考虑整个网络的布局: 如通信线缆的长度、走向、上位机的位置、网络末端的匹配电阻、通信转换器、网络可扩展性、网络覆盖范围、环境的电磁干扰情况等因素, 都要综合考虑。

The meter adapts MODBUS-RTU protocol, and the baud rate can be chosen from 1200bps, 2400 bps, 4800 bps, 9600bps, 19200bps and 38400 bps. The default parity is None.

The meter needs shielded twisted pair conductors to connect. Customers should consider the whole network's parameters such like communication wire's length, the direction, communication transformer and network cover range, etc.

注:

- 1、在布线工程上要严格按照要求施工;
- 2、对于暂时不需要通信的仪表都要将他们连接到 RS-485 网络上, 以便于诊断和测试;
- 3、进行 RS-485 电缆连接时, 尽量使用双色双绞线, 所有的 485 通信口 “A” 端接同一种颜色, “B” 端接另一种颜色。
- 4、RS-485 总线(从上位机通信口开始到任一被连接的仪表终端通信口)长不超过 1200 米。

Note:

- 1、Wiring should follow the wiring requirements;
- 2、Connect all the meter in the RS485 net work even some do not need to communication, which is benefit for error checking and testing;
- 3、Use two color wires in connecting wires and all the A port use the same color.
- 4、No longer than 1200 meters of RS485 bus line.

## 9.1 地址表 ADDR List

仪表支持 MODBUS-RTU 协议中的 03H 命令与 10H 命令，03H 为读多个寄存器，10H 为写多个寄存器，协议数据格式请自行查询。下表为仪表的寄存器地址表：

MODBUS-RTU protocol has 03H and 10H command to read and write registers respectively. The following chart is registers' address list.

表 7 通讯地址表  
Table 7 communication address list

地址 Address	名称 Variable	长度 Length	读/写 R/W	备注 Note
0000H	当前组合有功总电能 Current total active energy	4	R	整型 保留 2 位小数 单位 kWh (电压、电流、功率、电能数据均为电表实测数据，电表若存在变比，相关数据需乘以对应变比值) 如电能数值为 1234，PT 为 10，CT 为 20，则 $E=1234*0.01*10*20=2468.00\text{kWh}$ 其他数据如此计算 UINT32 Keep 2 decimal places. Unit kWh (The data of voltage, current, power and electric energy are all measured data of the meter. Particularly, if there is a transformation ratio of the meter, the relevant data shall be multiplied by the corresponding transformation ratio.) If the electric energy value is 1234, Pt is 10, CT is 20, Then $E = 1234 * 0.01 * 10 * 20 = 2468.00\text{kwh}$ . Other data are calculated as above.
0002H	当前组合有功尖电能 Current spike electric energy	4	R	
0004H	当前组合有功峰电能 Current peak electric energy	4	R	
0006H	当前组合有功平电能 Current flat electric energy	4	R	
0008H	当前组合有功谷电能 Current valley electric energy	4	R	
000AH	当前正向总有功电能 Current forward active total electric energy	4	R	
000CH	当前正向有功尖电能 Current forward active spike electric energy	4	R	
000EH	当前正向有功峰电能 Current forward active peak electric energy	4	R	
0010H	当前正向有功平电能 Current forward active flat electric energy	4	R	
0012H	当前正向有功谷电能 Current forward active valley electric energy	4	R	
0014H	当前反向总有功电能 Current reversing active total electric energy	4	R	
0016H	当前反向有功尖电能 Current reversing active spike electric energy	4	R	
0018H	当前反向有功峰电能 Current reversing Active peak electric energy	4	R	
001AH	当前反向有功平电能 Current reversing active flat electric energy	4	R	
001CH	当前反向有功谷电能 Current reversing Active valley electric energy	4	R	
001EH	当前组合无功总电能 Current total reactive electric energy	4	R	整型 保留 2 位小数

0020H	当前组合无功尖电能 Current total reactive spike electric energy	4	R	单位 kvarh UINT32 Keep 2 decimal places Particularly, note the same as above.
0022H	当前组合无功峰电能 Current total reactive peak electric energy	4	R	
0024H	当前组合无功平电能 Current total reactive flat electric energy	4	R	
0026H	当前组合无功谷电能 Current total reactive valley electric energy	4	R	
0028H	当前正向总无功电能 Current forward reactive total electric energy	4	R	
002AH	当前正向无功尖电能 Current forward reactive spike electric energy	4	R	
002CH	当前正向无功峰电能 Current forward reactive spike electric energy	4	R	
002EH	当前正向无功平电能 Current forward reactive flat electric energy	4	R	
0030H	当前正向无功谷电能 Current forward reactive valley electric energy	4	R	
0032H	当前反向总无功电能 Current reversing reactive total electric energy	4	R	
0034H	当前反向无功尖电能 Current reversing reactive spike electric energy	4	R	
0036H	当前反向无功峰电能 Current reversing reactive peak electric energy	4	R	
0038H	当前反向无功平电能 Current reversing reactive flat electric energy	4	R	
003AH	当前反向无功谷电能 Current reversing reactive valley electric energy	4	R	
003CH	时间：秒、分 Time: second、minute	2	R/W	
003DH	时间：时、日 Time: hour、day	2	R/W	
003EH	时间：月、年 Time: month、year	2	R/W	
003FH	通信地址（高 8 位） 波特率（低 8 位） Address (high 8 bit) Baud (low 8 bit)	2	R/W	波特率（baud）： 0: 1200 1: 2400 2: 4800 3: 9600 4: 19200 5: 38400
0040H	脉冲常数 pulse constant	2	R	
0041H	第 1 时区时段表号 第 1 时区起始日期：日 First time zone time period number Start date of the first time zone: Day	2	R/W	时段表号： 1: 第一套时段表 2: 第二套时段表 3: 第三套时段表 4: 第四套时段表
0042H	第 1 时区起始日期：月 第 2 时区时段表号	2	R/W	Time zone number:

	Start date of the first time zone: month Second time zone time period number			1: First time zone 2: Second time zone 3: Third time zone 4: Fourth time zone
0043H	第 2 时区起始日期: 日 第 2 时区起始日期: 月 Start date of the second time zone: day Start date of the second time zone: month	2	R/W	
0044H	第 3 时区时段表号 第 3 时区起始日期: 日 Third time zone time period number Start date of the third time zone: day	2	R/W	
0045H	第 3 时区起始日期: 月 第 4 时区时段表号 Start date of the third time zone: month Fourth time zone time period number	2	R/W	
0046H	第 4 时区起始日期: 日 第 4 时区起始日期: 月 Start date of the fourth time zone: day Start date of the fourth time zone: month	2	R/W	
0047H-0060H	保留 Reserve			
0061H	A 相电压 Voltage of A phase	2	R	UINT16 分辨率: 0.1V Resolution: 0.1V
0062H	B 相电压 Voltage of B phase	2	R	
0063H	C 相电压 Voltage of C phase	2	R	
0064H	A 相电流 Current of A phase	2	R	UINT16 分辨率: 0.01A Resolution: 0.01A
0065H	B 相电流 Current of B phase	2	R	
0066H	C 相电流 Current of C phase	2	R	
0067H-0076H	保留 Reserve			
0077H	频率 frequency	2	R	分辨率: 0.01 Resolution: 0.01
0078H	A-B 线电压 Voltage between A-B	2	R	分辨率: 0.1V UINT16 Resolution: 0.1V
0079H	C-B 线电压 Voltage between C-B	2	R	
007AH	A-C 线电压 Voltage between A-C	2	R	
007BH	正向有功最大需量 Forward active maximum demand	2	R	分辨率: 0.001 Resolution: 0.001
007CH	发生时间: 分、时 Time of occurrence for the forward active maximum amount:minute、hour	2	R	
007DH	发生时间: 日、月 Time of occurrence for the forward active maximum amount:day、month	2	R	
007EH	反向有功最大需量 Reversing active maximum demand	2	R	
007FH	发生时间: 分、时 Time of occurrence for the Reversing active maximum demand amount:minute、hour	2	R	
0080H	发生时间: 日、月	2	R	

	Time of occurrence for the Reversing active maximum demand amount:day、 month			
0081H	正向无功最大需量 Maximum forward demand for reactive power	2	R	
0082H	发生时间：分、时 Time of occurrence for the forward reactive maximum amount:minute、 hour	2	R	
0083H	发生时间：日、月 Time of occurrence for the forward reactive maximum amount:day、 month	2	R	
0084H	反向无功最大需量 Maximum reversing demand for reactive power	2	R	
0085H	发生时间：分、时 Time of occurrence for the reversing reactive maximum amount:minute、 hour	2	R	
0086H	发生时间：日、月 Time of occurrence for the reversing reactive maximum amount:day、 month	2	R	
0087H	A 相正向有功电能 Forward active electric energy of A phase	4	R	整型 保留两位小数 kWh UINT32 Keep 2 decimal places
0089H	B 相正向有功电能 Forward active electric energy of B phase	4	R	
008BH	C 相正向有功电能 Forward active electric energy of C phase	4	R	
008DH	PT	2	R/W	
008EH	CT	2	R/W	
008FH	保留 Reserve			
0092H	零序电流 Zero sequence current	2	R	Resolution: 0.01A
0093H	电压不平衡度 Voltage imbalance	2	R	整型 分辨率：0.001 UINT16 Resolution: 0.001
0094H	电流不平衡度 Current imbalance	2	R	
0095H	校验位（高 8 位） 停止位（低 8 位） Parity bit（high 8 bit） Stop bit（low 8 bit）	2	R/W	校验位（parity bit）： 0：无校验（None） 1：奇校验（Odd） 2：偶校验（Even） 停止位（stop bit）： 0：1 位停止位（one stop bit） 1：2 位停止位（two stop bit）
0096H-0098H	保留 Reserve			
0099H-009EH	DL/T645 地址 DL/T645Address	12	R/W	BCD 码 BCD code
009FH-00A5H	保留 reserve			

00A6H	密码 Code	2	R/W	1-9999
00A7H-00B1	保留 reserve			
00B2H ... 00BAH	9-14 时段参数设置信息 9-14 period of time Parameters setting information			第一套时段表: The first time list
00BBH ... 00C3H	9-14 时段参数设置信息 9-14 period of time Parameters setting information			第二套时段表 The second time list
00C4H-00C9H	保留 Reserve			
00CAH	背光时间 The back light time	2	R/W	1-255 分钟, 0 常亮 1-255minutes, 0 means always on
00CBH-0120H	保留 Reserve			
0121H	日冻结时间:时 Daily frozen time:Hour	2	R/W	
0122H	月冻结:日、时 Monthly frozetime:day、hour	2	R/W	
0123H-0163H	保留 Reserve			
0164H	A 相有功功率 Active power of A phase	4	R	有符号整型 分辨率: 0.001kW INT32 Resolution: 0.001kW
0166H	B 相有功功率 Active power of B phase	4	R	
0168H	C 相有功功率 Active power of C phase	4	R	
016AH	总有功功率 Total active power	4	R	
016CH	A 相无功功率 Reactive power of A phase	4	R	有符号整型 分辨率: 0.001kvar INT32 Resolution: 0.001kvar
016EH	B 相无功功率 Reactive power of B phase	4	R	
0170H	C 相无功功率 Reactive power of C phase	4	R	
0172H	总无功功率 Total reactive power	4	R	
0174H	A 相视在功率 Apparent power of A phase	4	R	无符号整型 分辨率: 0.001kVA UINT32 Resolution: 0.001kVA
0176H	B 相视在功率 Apparent power of B phase	4	R	
0178H	C 相视在功率 Apparent power of C phase	4	R	
017AH	总视在功率 Total apparent power	4	R	
017CH	A 相功率因数 Power factor of A phase	2	R	有符号整型 分辨率: 0.001 INT16 Resolution: 0.001
017DH	B 相功率因数 Power factor of B phase	2	R	
017EH	C 相功率因数 Power factor of C phase	2	R	
017FH	总功率因数 Total power factor	2	R	
0180H	当日正向有功最大需量 Maximum forward active demand a day	2	R	

0181H	发生时间：分、时 Occur time:minute、hour	2	R
0182H	当日反向有功最大需量 Maximum reversing active demand a day	2	R
0183H	发生时间：分、时 Maximum reversing active demand a day	2	R
0184H	当日正向无功最大需量 Maximum forward reactive demand a day	2	R
0185H	发生时间：分、时 Occur time:minute、hour	2	R
0186H	当日反向无功最大需量	2	R
0187H	发生时间：分、时 Occur time:minute、hour	2	R
0188H	上1日正向有功最大需量 Maximum forward active demand last day	2	R
0189H	发生时间：分、时 Occur time:minute、hour	2	R
018AH	上1日反向有功最大需量 Maximum reversing active demand last day	2	R
018BH	发生时间：分、时 Occur time:minute、hour	2	R
018CH	上1日正向无功最大需量 Maximum forward reactive demand last day	2	R
018DH	发生时间：分、时 Occur time:minute、hour	2	R
018EH	上1日反向无功最大需量 Maximum reversing reactive demand last day	2	R
018FH	发生时间：分、时 Occur time:minute、hour	2	R
0190H	上2日正向有功最大需量 Maximum forward active demand last 2 days	2	R
0191H	发生时间：分、时 Occur time:minute、hour	2	R
0192H	上2日反向有功最大需量 Maximum reversing active demand last 2 days	2	R
0193H	发生时间：分、时 Occur time:minute、hour	2	R
0194H	上2日正向无功最大需量 Maximum forward reactive demand last 2 days	2	R
0195H	发生时间：分、时 Occur time:minute、hour	2	R
0196H	上2日反向无功最大需量 Maximum reversing reactive demand last 2 days	2	R
0197H	发生时间：分、时	2	R

分辨率：0.001  
发生时间：分、时  
Resolution：0.001  
Occur time:minute、hour

	Occur time:minute、hour		
0198H	当前正向有功需量 Current forward active demand	2	R
0199H	当前反向有功需量 Current reversing active demand	2	R
019AH	当前正向无功需量 Current forward reactive demand	2	R
019BH	当前反向无功需量 Current reversing reactive demand	2	R
019CH-01FFH	保留 Reserve		
0200H	A 相电压极大值 Maximum voltage on A phase	2	R
0201H	发生时间: 月、日 Occur date: month、day	2	R
0202H	发生时间: 时、分 Occur time: hour、minute	2	R
0203H	B 相电压极大值及发生时间 Maximum voltage on B phase and occur time	6	R
0206H	C 相电压极大值及发生时间 Maximum voltage on C phase and occur time	6	R
0209H	A 相电流极大值及发生时间 Maximum current on A phase and occur time	6	R
020CH	B 相电流极大值及发生时间 Maximum current on B phase and occur time	6	R
020FH	C 相电流极大值及发生时间 Maximum current on B phase and occur time	6	R
0212H	A 相有功功率极大值 Maximum active power on A phase	4	R
0214H	发生时间: 月、日 Occur data: month、day	2	R
0215H	发生时间: 时、分 Occur time: hour、minute	2	R
0216H	B 相有功功率极大值及发生时间 Maximum active power on B phase and occur time	8	R
021AH	C 相有功功率极大值及发生时间 Maximum active power on C phase and occur time	8	R
021EH	总有功功率极大值及发生时间 Maximum active power and occur time	8	R
0222H	A 相无功功率极大值及发生时间 Maximum reactive power on A phase and occur time	8	R
0226H	B 相无功功率极大值及发生时间 Maximum reactive power on B phase and occur time	8	R

022AH	C 相无功功率极大值及发生时间 Maximum reactive power on C phase and occur time	8	R
022EH	总无功功率极大值及发生时间 Maximum reactive power and occur time	8	R
0232H	A 相视在功率极大值及发生时间 Maximum apparent power on A phase and occur time	8	R
0236H	B 相视在功率极大值及发生时间 Maximum apparent power on B phase and occur time	8	R
023AH	C 相视在功率极大值及发生时间 Maximum apparent power on C phase and occur time	8	R
023EH	总视在功率极大值及发生时间 Maximum apparent power and occur time	8	R
0242H	A 相电压极小值及发生时间 Minimum voltage on A phase and occur time	6	R
0245H	B 相电压极小值及发生时间 Minimum voltage on B phase and occur time	6	R
0248H	C 相电压极小值及发生时间 Minimum voltage on C phase and occur time	6	R
024BH	A 相电流极小值及发生时间 Minimum current on A phase and occur time	6	R
024EH	B 相电流极小值及发生时间 Minimum current on B phase and occur time	6	R
0251H	C 相电流极小值及发生时间 Minimum current on C phase and occur time	6	R
0254H	A 相有功功率极小值及发生时间 Minimum active power on A phase and occur time	8	R
0258H	B 相有功功率极小值及发生时间 Minimum active power on B phase and occur time	8	R
025CH	C 相有功功率极小值及发生时间 Minimum active power on C phase and occur time	8	R
0260H	总有功功率极小值及发生时间 Minimum active power and occur time	8	R
0264H	A 相无功功率极小值及发生时间 Minimum reactive power on A phase and occur time	8	R
0268H	B 相无功功率极小值及发生时间 Minimum reactive power on B phase and occur time	8	R
026CH	C 相无功功率极小值及发生时间	8	R

	Minimum reactive power on C phase and occur time			
0270H	总无功功率极小值及发生时间 Minimum reactive power and occur time	8	R	
0274H	A 相视在功率极小值及发生时间 Minimum apparent power on A phase and occur time	8	R	
0278H	B 相视在功率极小值及发生时间 Minimum apparent power on B phase and occur time	8	R	
027EH	C 相视在功率极小值及发生时间 Minimum apparent power on C phase and occur time	8	R	
0280H	总视在功率极小值及发生时间 Minimum apparent power and occur time	8	R	
0285H-1FFFH	保留 Reserve			
F009H	设备型号 Device model	2	R	A400(HEX)

## 9.2 浮点型电参量数据 Floating point electrical parameter data

Table 8 Float data communication address list

地址 Address	数据名称 Name	长度 Length	R/W	备注 Note
<b>二次侧数据不含变比 Secondary side data without multiplication of the variable ratio</b>				
5300H	A 相电压 Voltage of A phase	4	R	Float Unit:V
5302H	B 相电压 Voltage of B phase	4	R	
5304H	C 相电压 Voltage of C phase	4	R	
5306H	A-B 线电压 Voltage between A-B	4	R	
5308H	C-B 线电压 Voltage between C-B	4	R	
530AH	A-C 线电压 Voltage between A-C	4	R	
530CH	A 相电流 Current of A phase	4	R	Float Unit:A
530EH	B 相电流 Current of B phase	4	R	
5310H	C 相电流 Current of C phase	4	R	
5312H	A 相有功功率 Active power of A phase	4	R	Float Unit:W
5314H	B 相有功功率 Active power of B phase	4	R	
5316H	C 相有功功率 Active power of C phase	4	R	
5318H	总有功功率 Total active power	4	R	
531AH	A 相无功功率 Reactive power of A phase	4	R	Float Unit:var
531CH	B 相无功功率 Reactive power of B phase	4	R	
531EH	C 相无功功率 Reactive power of C phase	4	R	
5320H	总无功功率 Total reactive power	4	R	
5322H	A 相视在功率 Apparent power of A phase	4	R	Float Unit:VA
5324H	B 相视在功率	4	R	

	Apparent power of B phase			
5326H	C 相视在功率 Apparent power of C phase	4	R	
5328H	总视在功率 Total apparent power	4	R	
532AH	A 相功率因数 Power factor of A phase	4	R	Float
532CH	B 相功率因数 Power factor of B phase	4	R	
532EH	C 相功率因数 Power factor of C phase	4	R	
5330H	总功率因数 Total power factor	4	R	
5332H	频率 frequency	4	R	
5334H	零序电流 zero line current	4	R	Float Unit:A
<b>一次侧数据含变比 Primary side data that has been multiplied by the variable ratio</b>				
0800H	A 相电压 Voltage of A phase	4	R	Float Unit:V
0802H	B 相电压 Voltage of B phase	4	R	
0804H	C 相电压 Voltage of C phase	4	R	
0806H	A-B 线电压 Voltage between A-B	4	R	
0808H	C-B 线电压 Voltage between C-B	4	R	
080AH	A-C 线电压 Voltage between A-C	4	R	
080CH	A 相电流 Current of A phase	4	R	Float Unit:A
080EH	B 相电流 Current of B phase	4	R	
0810H	C 相电流 Current of C phase	4	R	
0812H	零序电流 zero line current	4	R	
0814H	A 相有功功率 Active power of A phase	4	R	Float Unit:kW
0816H	B 相有功功率 Active power of B phase	4	R	
0818H	C 相有功功率 Active power of C phase	4	R	
081AH	总有功功率 Total active power	4	R	
081CH	A 相无功功率 Reactive power of A phase	4	R	Float Unit:kvar
081EH	B 相无功功率 Reactive power of B phase	4	R	
0820H	C 相无功功率 Reactive power of C phase	4	R	
0822H	总无功功率 Total reactive power	4	R	
0824H	A 相视在功率 Apparent power of A phase	4	R	Float Unit:kVA
0826H	B 相视在功率 Apparent power of B phase	4	R	
0828H	C 相视在功率 Apparent power of C phase	4	R	
082AH	总视在功率 Total apparent power	4	R	
082CH	A 相功率因数 Power factor of A phase	4	R	Float
082EH	B 相功率因数 Power factor of B phase	4	R	
0830H	C 相功率因数 Power factor of C phase	4	R	
0832H	总功率因数 Total power factor	4	R	
0834H	频率 frequency	4	R	Float Unit:Hz
0836H	电压不平衡度 Voltage imbalance	4	R	Float Unit:0.1

0838H	电流不平衡度 Current imbalance	4	R	Float Unit:0.1
083AH	当前正向有功最大需量 Current forward active demand	4	R	Float Unit:kW
083CH	当前反向有功最大需量 Current reversing active demand	4	R	
083EH	当前正向无功最大需量 Current forward reactive demand	4	R	Float Unit:kvar
0840H	当前反向无功最大需量 Current reversing reactive demand	4	R	
0842H	当前组合有功总电能 Current total active energy	4	R	整型 保留一位小数 (一次侧数据) UINT32 Resolution: 0.1kWh Primary side data
0844H	当前组合有功尖电能 Current spike electric energy	4	R	
0846H	当前组合有功峰电能 Current peak electric energy	4	R	
0848H	当前组合有功平电能 Current flat electric energy	4	R	
084AH	当前组合有功谷电能 Current valley electric energy	4	R	
084CH	当前正向总有功电能 Current forward active total electric energy	4	R	
084EH	当前正向有功尖电能 Current forward active spike electric energy	4	R	
0850H	当前正向有功峰电能 Current forward active peak electric energy	4	R	
0852H	当前正向有功平电能 Current forward active flat electric energy	4	R	
0854H	当前正向有功谷电能 Current forward active valley electric energy	4	R	
0856H	当前反向总有功电能 Current reversing active total electric energy	4	R	
0858H	当前反向有功尖电能 Current reversing active spike electric energy	4	R	
085AH	当前反向有功峰电能 Current reversing Active peak electric energy	4	R	
085CH	当前反向有功平电能 Current reversing active flat electric energy	4	R	
085EH	当前反向有功谷电能 Current reversing Active valley electric energy	4	R	
0860H	当前组合无功总电能 Current total reactive electric energy	4	R	整型 保留一位小数 (一次侧数据) UINT32 Resolution: 0.1kvarh
0862H	当前组合无功尖电能 Current total reactive spike electric energy	4	R	
0864H	当前组合无功峰电能 Current total reactive peak electric energy	4	R	

0866H	当前组合无功平电能 Current total reactive flat electric energy	4	R	Primary side data
0868H	当前组合无功谷电能 Current total reactive valley electric energy	4	R	
086AH	当前正向总无功电能 Current forward reactive total electric energy	4	R	
086CH	当前正向无功尖电能 Current forward reactive spike electric energy	4	R	
086EH	当前正向无功峰电能 Current forward reactive spike electric energy	4	R	
0870H	当前正向无功平电能 Current forward reactive flat electric energy	4	R	
0872H	当前正向无功谷电能 Current forward reactive valley electric energy	4	R	
0874H	当前反向总无功电能 Current reversing reactive total electric energy	4	R	
0876H	当前反向无功尖电能 Current reversing reactive spike electric energy	4	R	
0878H	当前反向无功峰电能 Current reversing reactive peak electric energy	4	R	
087AH	当前反向无功平电能 Current reversing reactive flat electric energy	4	R	
087CH	当前反向无功谷电能 Current reversing reactive valley electric energy	4	R	

### 9.3 历史电能冻结时间设定及历史电能数据

#### History energy frozen time and history energy energy date

DEMUR-AC3 日冻结时间设定寄存器、月冻结日期设定寄存器。

DEMUR-AC3's registers on frozen by day and by month.

表 9 冻结时间通讯地址表

Table 9 Frozen time communication address

地址 Address	名称 Name	R/W	备注 Note
0121H	日冻结时间 Frozen time by day	R/W	无效 (高字节) 抄表时 (低字节) Null (High byte) Hour(Low byte)
0122H	月冻结时间 Frozen time by month	R/W	抄表日 (高字节) 抄表时 (低字节) Day(High byte) Hour(Low byte)

DEMUR-AC3 能统计上 48 月的历史电能 (各费率电能)。

DEMUR-AC3 能统计上 90 日的历史电能 (各费率电能)。

历史电能可以通过块读取，长度为 68 个字节(34 个寄存器)，每块的顺序和内容如下：

DEMR-AC3 can achieve the history energy statistic in last 48 months and last 90days. (Each tariff rate of energy can be recorded.)The history energy record can be read by assemblage and the length of whole part is 68 byte (34 registers), and the list below is the registers' name.

表 10 历史电能通讯地址表

Table 10 History energy communication address

地址 Address	名称 Name	数据顺序 Data list	名称 Name	备注 Note
6000H	上 1 月电能及需量块 Assemblage of last 1 month demand and energy	6000H	冻结时间：年-月 Frozen time:YY-MM	
6022H	上 2 月电能及需量块 Assemblage of last 2 months demand and energy	6001H	冻结时间：日-时 Frozen time: DD-hh	
...	...	6002H	总有功电能 Total active energy	整型 保留两位小数 二次侧数据 kWh UINT32 Keep 2 decimal places (Secondary side data)
6BD2H	上 48 月电能及需量块 Assemblage of last 48 months demand and energy	6004H	有功尖电能 Spike active energy	
reserve	保留 reserve	6006H	有功峰电能 Peak active energy	
7000H	上 1 日电能及需量块 Assemblage of last 1 day demand and energy	6008H	有功平电能 Flat active energy	
7022H	上 2 日电能及需量块 Assemblage of last 2days demand and energy	600AH	有功谷电能 Valley active energy	
...	...	600CH	总无功电能 Total reactive energy	整型 保留两位小数 二次侧数据 Kvarh UINT32 Keep 2 decimal places (Secondary side data)
763EH	上 90 日电能及需量块 Assemblage of last 90days demand and energy	600EH	无功尖电能 Spike reactive energy	
		6010H	无功峰电能 Peak reactive energy	
		6012H	无功平电能 Flat reactive energy	
		6014H	无功谷电能 Valley reactive energy	
		6016H	A 相正向有功电能 Total amount of phase A forward active energy	整型 保留两位小数 二次侧数据 kWh UINT32 Keep 2 decimal places (Secondary side data)
		6018H	B 相正向有功电能 Total amount of phase B forward active energy	
		601AH	C 相正向有功电能	

	Total amount of phase C forward active energy	
601CH	有功最大需量 Maximum active demand	整型 二次侧数据 Resolution: 0.001kW (Secondary side data)
601DH	发生时间: 分、时 Occurrence time: mm-hh	
601EH	发生时间: 日、月 Occurrence time : DD-MM	
601FH	无功最大需量 Maximum reactive demand	整型 二次侧数据 Resolution: 0.001kvar (Secondary side data)
6020H	发生时间: 分、时 Occurrence time: mm-hh	
6021H	发生时间: 日、月 Occurrence time: DD-MM	

#### 9.4 分次谐波数据 Sub-harmonic data

DEMR-AC3 可测量谐波, 统计分相 2-31 次谐波电压电流、总谐波畸变率、分相谐波电压电流、分相谐波有功功率无功功率、分相基波电流电压、分相基波有功功率无功功率。

DEMR-AC3 can measure harmonics, statistics split-phase 2-31st harmonic voltage and current, total harmonic distortion rate, split-phase harmonic voltage and current, split-phase harmonic active power and reactive power, split-phase fundamental current and voltage, split-phase fundamental active and power reactive power.

表 11 分次谐波数据地址表

Table 11 Harmonics data address list

地址 Address	名称 Name	长度(字节) Length(byte)	R/W	备注 Note
05DDH	THDUa	2	R	分相电压电流总畸变率 整型, 保留 2 位小数 Total distortion rate of voltage and current on each phase UINT16 Resolution: 0.01%
05DEH	THDUB	2	R	
05DFH	THDUC	2	R	
05E0H	THDIa	2	R	
05E1H	THDIb	2	R	
05E2H	THDIc	2	R	
05E3H	THUa	2×30	R	电压分相 2~31 次谐波含量 整型 保留 2 位小数 Harmonic voltage on 2 <sup>nd</sup> -31 <sup>st</sup> UINT16 Resolution: 0.01%
0601H	THUb	2×30	R	
061FH	THUc	2×30	R	
063DH	THIa	2×30	R	电流分相 2~31 次谐波含量 整型, 保留 2 位小数 Harmonic current on 2 <sup>nd</sup> -31 <sup>st</sup> UINT16 Resolution: 0.01%
065BH	THIb	2×30	R	
0679H	THIc	2×30	R	
0697H	A 相基波电压 Fundamental voltage on A phase	2	R	整型 保留 1 位小数 UINT16 Resolution: 0.1V
0698H	B 相基波电压 Fundamental voltage on B phase	2	R	
0699H	C 相基波电压	2	R	

	Fundamental voltage on C phase			
069AH	A 相谐波电压 Harmonic voltage on A phase	2	R	
069BH	B 相谐波电压 Harmonic voltage on B phase	2	R	
069CH	C 相谐波电压 Harmonic voltage on C phase	2	R	
069DH	A 相基波电流 Fundamental current on A phase	2	R	整型 保留 2 位小数 UINT16 Resolution: 0.01A
069EH	B 相基波电流 Fundamental current on B phase	2	R	
069FH	C 相基波电流 Fundamental current on C phase	2	R	
06A0H	A 相谐波电流 Harmonic current on A phase	2	R	
06A1H	B 相谐波电流 Harmonic current on B phase	2	R	
06A2H	C 相谐波电流 Harmonic current on C phase	2	R	
06A3H	A 相基波有功功率 Fundamental active power on A phase	2	R	整型 保留 3 位小数 INT16 Resolution: 0.001kW
06A4H	B 相基波有功功率 Fundamental active power on B phase	2	R	
06A5H	C 相基波有功功率 Fundamental active power on C phase	2	R	
06A6H	总基波有功功率 Fundamental active power	2	R	
06A7H	A 相基波无功功率 Fundamental reactive power on A phase	2	R	整型 保留 3 位小数 INT16 Resolution: 0.001kvar
06A8H	B 相基波无功功率 Fundamental reactive power on B phase	2	R	
06A9H	C 相基波无功功率 Fundamental reactive power on C phase	2	R	
06AAH	总基波无功功率 Fundamental reactive power	2	R	
06ABH	A 相谐波有功功率 Harmonic active power on A phase	2	R	整型 保留 3 位小数 INT16 Resolution: 0.001kW
06ACH	B 相谐波有功功率 Harmonic active power on B phase	2	R	

	phase			
06ADH	C 相谐波有功功率 Harmonic active power on C phase	2	R	
06AEH	总谐波有功功率 Harmonic active power	2	R	
06AFH	A 相谐波无功功率 Harmonic reactive power on A phase	2	R	整型 保留 3 位小数 INT16 Resolution: 0.001kvar
06B0H	B 相谐波无功功率 Harmonic reactive power on B phase	2	R	
06B1H	C 相谐波无功功率 Harmonic reactive power on C phase	2	R	
06B2H	总谐波无功功率 Harmonic reactive power	2	R	

### 9.5 SOE 事件记录 SOE Record

地址 Address	名称 Name	数据顺序 Data list	名称 Name
3001H	上 1 次事件记录 Last event record	0000H	事件发生: 年-月 Occur date: YY-MM
3002H	上 2 次事件记录 Last 2 event record	0001H	事件发生: 日-时 Occur time: DD-hh
...	...	0002H	事件发生: 分-秒 Occur time: mm-ss
3064H	上 100 次事件记录 Last 100 event record	0004H	事件编号 Event number
		0005H	事件详情 Event details
		0006H	预留 Reserve

事件编号 Event num	名称 Name	事件详情 Details	备注 Note
0100	上电事件 Power on		
0200	清零事件 Clear	0001	当前电能清零 Clear current energy
		0002	Flash 历史电能清零 Clear history energy on Flash
		0003	最大需量清零

0700	校时 Time calibration

	Clear maximum demand
0004	历史电能清零 Clear history energy
0005	极值清零 Clear maximum value on a period
0006	全清零 Clear out

如当前仪表地址为 001，读取上 1 条事件记录主站发送：01 03 30 01 00 06 9B 08，从站回复为：01 03 0C 12 01 08 0A 01 01（18 年 1 月 8 日 10 时 1 分 1 秒）01 00（上电）00 00（上电事件无事件详情）00 00（预留）80 23。

Example: The address is 001 at present, and we send the code: 01 03 30 01 00 06 9B 08 to get the last event record, and the slave station will give back: 01 03 0C 12 01 08 0A 01 01 (2018/1/8 10:1:1) 01 00 (powered) 00 00 (no details) 00 00 (reserved) 80 23