

未注公差/General tolerances (mm)													0.1/10	
0 ~ 3	>3 ~ 6	>6 ~ 10	>10 ~ 18	>18 ~ 30	>30 ~ 50	>50 ~ 80	>80 ~ 120	>120 ~ 180	>180 ~ 250	>250 ~ 315	>315 ~ 400	>400 ~ 500		>500
±0.12	±0.18	±0.22	±0.26	±0.31	±0.37	±0.57	±0.80	±0.93	±1.05	±1.15	±1.60	±2.20	±2.50	±2'

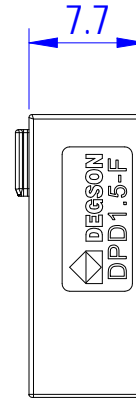
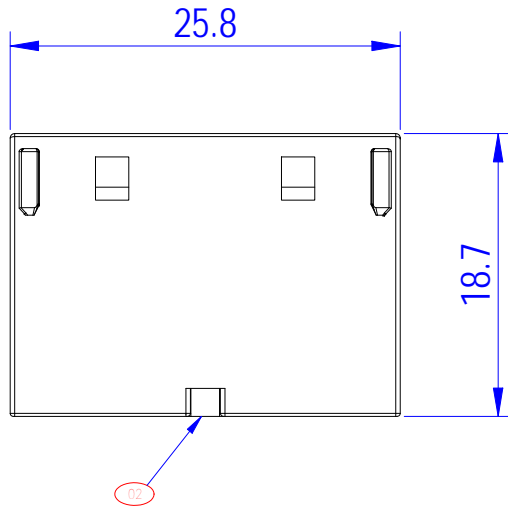
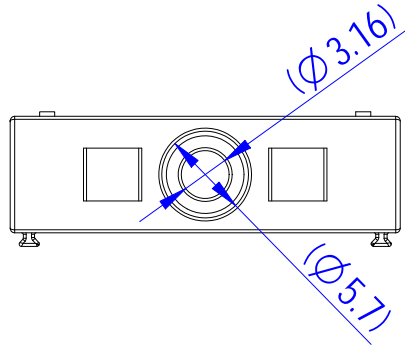

1	Housing	PA66	UL94 V-0
ITEM	NAME OF PART	MATERIAL	NOTES
使用温度范围/Operating temperature(°C)			-40~+105
符合RoHS环保要求/Conform to RoHS			Yes

		MATERIAL: PA66	SURFACE/COLOR:						
		MAT NO./REV: /	MAT STATUS: 小批量						
APPD: 彭敏	2025.09.16	NAME							
CHKD: 高卫国	2025.09.16	DPD1.5-F-1Y-00Z (H)							
DRFT: 陈科泽	2025.09.15								
REV	ECN	DESCRIPTION	DRFT	DATE	DRAWING NO.	TYPE	DRAWING STATUS	SCALE	SHEET
		Increase the engagement strength, update the snap-fix structure	陈科泽	2025.09.15	200322471	CUSTOMER DRAWING	已发布	5:1	1/1

02		Increase the engagement strength, update the snap-fix structure	陈科泽	2025.09.15
REV	ECN	DESCRIPTION	DRFT	DATE

Transfer or duplication of this document as well as the utilization or communication of its content are prohibited unless expressly permitted. Violations will be treated as counterfeiting. All rights reserved for patent, utility model or design registrations. 除特别说明外，本文件的所有内容均受专利、实用新型、外观设计、发明专利、软件著作权等知识产权的保护。未经许可，不得擅自复制或传播。