

Transfer or duplication of this document as well as the utilization or communication of its contents are prohibited unless authorized in writing. All rights reserved for patent, utility model or design registrations. 除专利等明确标注外，本文件内容均受法律保护。未经书面许可，不得复制或传播。 0.05/10

未注公差/General tolerances(mm)												0.05/10		
0	>3	>6	>10	>18	>30	>50	>80	>120	>180	>250	>315		>400	>500
±0.08	±0.12	±0.18	±0.22	±0.26	±0.31	±0.37	±0.57	±0.80	±0.93	±1.05	±1.15	±1.60	±2.20	±1

重点管控符号/Key controlled symbol	*
拆装寿命/Plug number	≥100
包装规范/Packaging specification	SOP-Y-3253
使用温度范围/Operating temperature(°C)	-40~+105
螺丝盐雾/Salt mist	500小时
橡胶硬度/Rubber hardness	HA55~70
螺丝建议扭力/Twisting force	1.2 N.m
防护等级/Level protection	IP66
是否符合ROHS环保要求/Conform to RoHS	yes

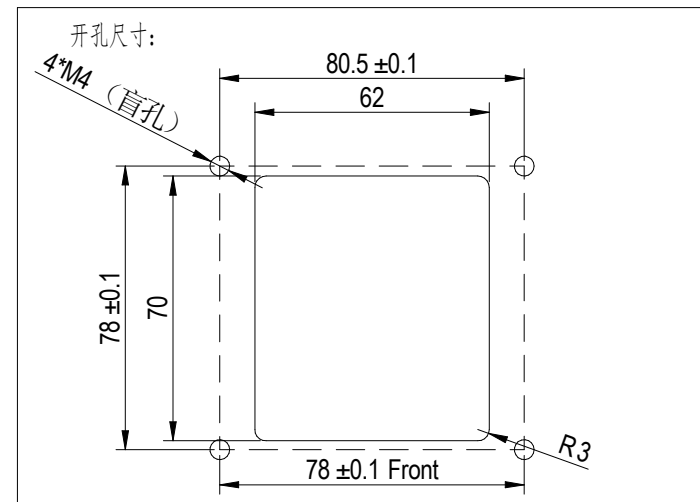
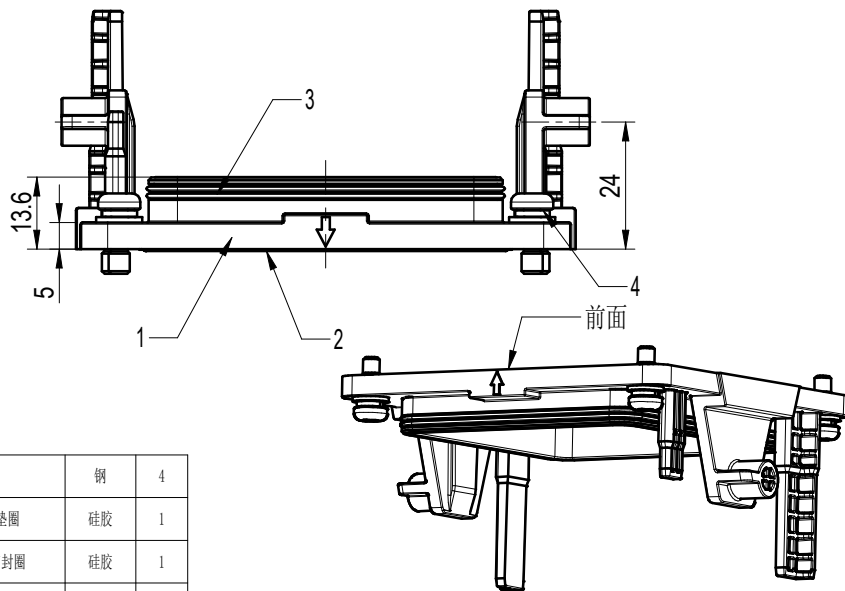
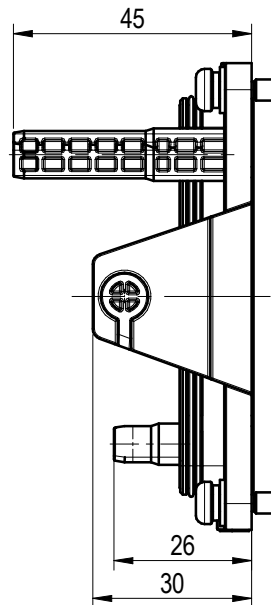
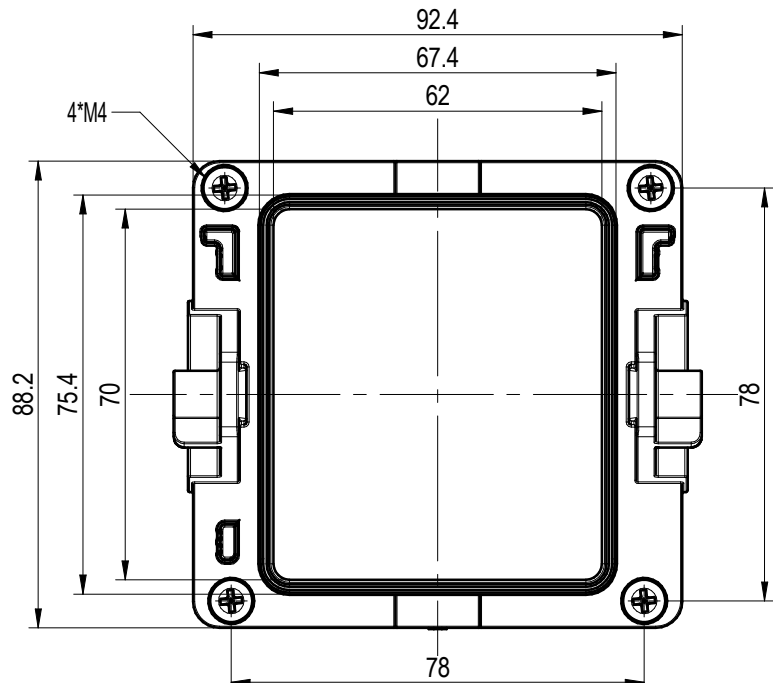

4	M4*12	钢	4
3	9芯防水罩底座-垫圈	硅胶	1
2	9芯防水罩底座-密封圈	硅胶	1
1	9芯防水罩底座-主体	PC+20GF	1
序号	品名	材料	数量

00			王玉明	2024/05/31
REV	ECN	DESCRIPTION	DRFT	DATE

DEGSON		MATERIAL: 材质	SURFACE/COLOR: 表面处理		
		MAT NO./REV: 29030000024 / 00	MAT STATUS: 小批量		
APPD:		NAME			
CHKD:		PV-ST-F-PF-6-00ZH			
DRFT: 王玉明	2024/05/31	DRAWING NO. 200267221	TYPE CUSTOMER DRAWING	DRAWING STATUS 已发布	SHEET 1/1