

Recommended Panel Cut-Out

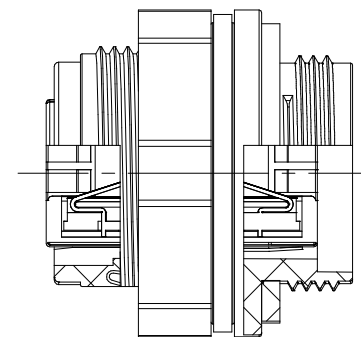

02 局部剖视图

01



MATERIAL:	General tolerances(mm): ISO 2768-mK
MAT NO./REV: 29030000077 / 00	MAT STATUS:

02		增加局部剖视图	Yu HX	2025/11/4	APPD:		NAME					
01		增加新视图, 底部结构变化, 品名大写	Yu HX	2024/11/8	CHKD:		DGK18-DOUBLE-RJ45-00A (H)					
00			Yu HX	2024/10/11	DRFT:	Yu HX	2024/11/8	DRAWING NO.	TYPE	DRAWING STATUS	SCALE	SHEET
REV	ECN	DESCRIPTION	DRFT	DATE	④	↖	A4	← 0.1mm (inch)	200318357	CUSTOMER DRAWING	1.2:1	1/1

Transfer or duplication of this document as well as the utilization or communication of its contents are prohibited unless authorized in writing. All rights reserved for patent, utility model or designer registrations. 除专利权明确标注, 否则禁止转让、复制、印刷、光碟等文件的传播。 未经授权, 禁止以任何形式复制或传播本文件内容。