

未注公差/General tolerances (mm)											0.1/10 ±2'		
0~3	>3~6	>6~10	>10~18	>18~30	>30~50	>50~80	>80~120	>120~180	>180~250	>250~315		>315~400	>400~500
±0.12	±0.18	±0.22	±0.26	±0.31	±0.37	±0.57	±0.80	±0.93	±1.05	±1.15	±1.60	±2.20	±2.50

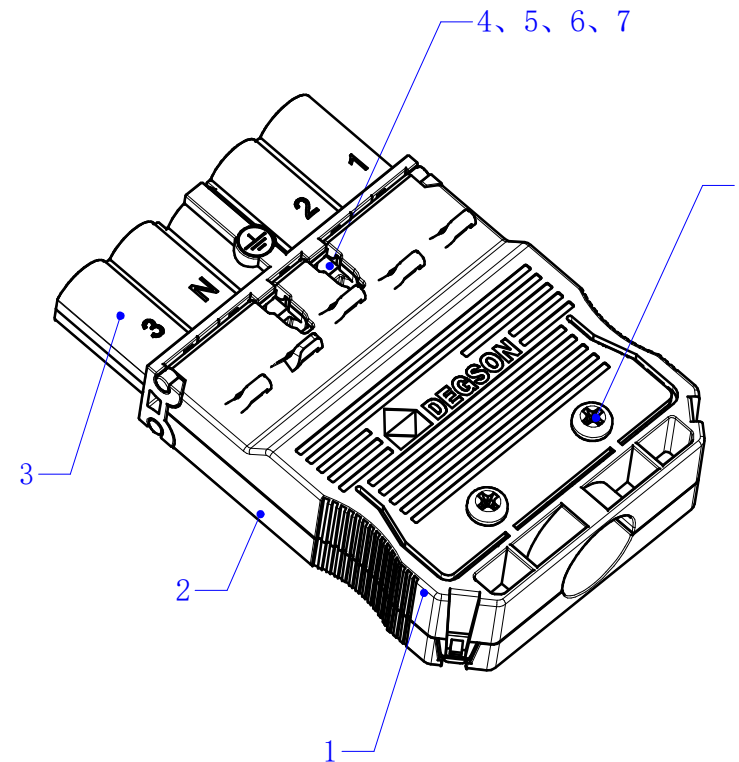
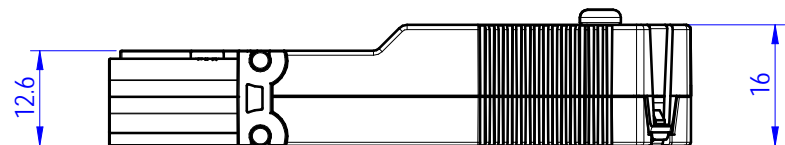
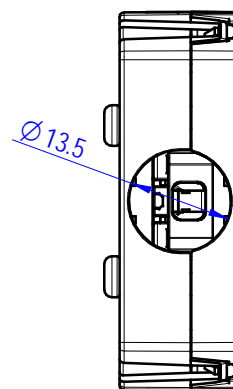
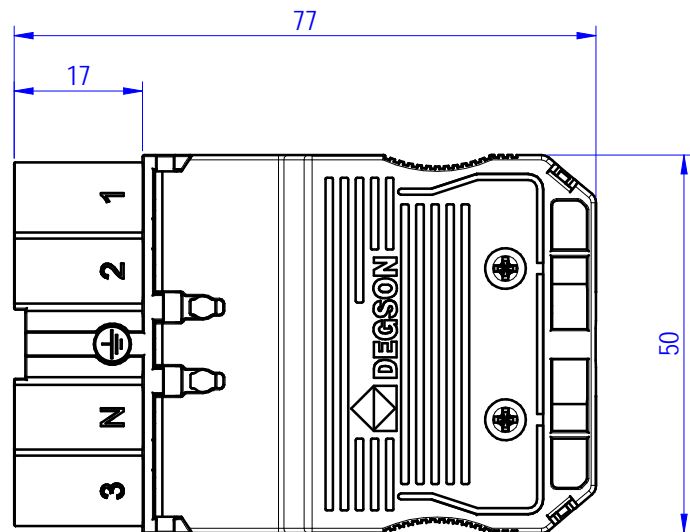
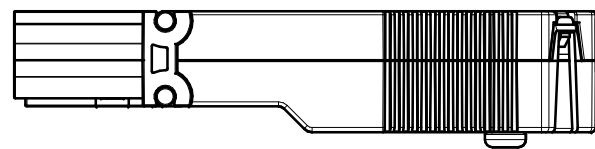
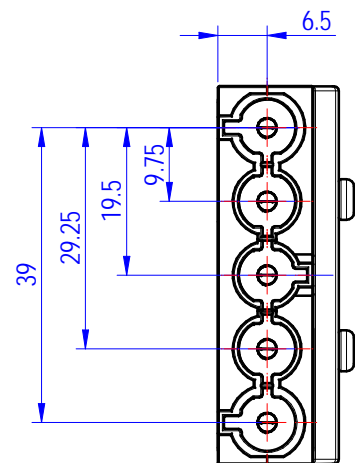

ITEM	NAME OF PART	MATERIAL	NOTES
8	Screw	Steel	Zn plated
7	Button	PA66+GF	UL94V-0
6	Spring	Stainless steel	/
5	Male pin	Copper alloy	Sn Plated
4	Cover	PA66+GF	UL94V-0
3	Housing	PA66+GF	UL94V-0
2	Bottom cover	PA66	UL94V-0
1	Top cover	PA66	UL94V-0

UL 标准/UL Standard: (UL1977)			
额定电压/电流/Rated Voltage(V)/Current(A)		600V/20A	
IEC 标准/IEC Standard:(IEC61535)			
额定电压/电流/Rated Voltage(V)/Current(A)		250/400V,32A	
额定脉冲电压(KV)/Rate Impulse Voltage(KV)		4	
螺丝扭矩/Torque Tightening(N·m/Lb.in)		ST2.9, 1.0/8.8	
线径范围(硬线和软线)/Wire Range(rigid and flexible)(AWG/mm²)		20~12 / 0.5~4	
间距/Pitch(mm)/线数范围/Poles		9.75/N=05P	
剥线长度/Stripping length(mm)		10~11	
使用温度范围/Operating temperature(°C)		-40~+105	

DEGSON MATERIAL: / SURFACE/COLOR: /
 MAT NO./REV: / /00 MAT STATUS: /

NAME: **DGBSC-PG01M/4-05P-1Y-00Z (H)**

APPD: 蓝贵凡	2025.05.12	DRAWING NO.	TYPE	DRAWING STATUS	SCALE	SHEET
CHKD: 朱伟明	2025.05.12	200344638	CUSTOMER DRAWING	/	1:1	1/1
DRFT: 汪德荣	2025.05.12					

REV	ECN	DESCRIPTION	DRFT	DATE
00	/		汪德荣	2025.05.12

Transfer or duplication of this document as well as the utilization or communication of its contents are prohibited unless explicit authorization is granted. Violations will be liable for compensation. All rights reserved for patent, utility model or design registrations. 除经本公司书面许可外, 复制或传播本文件内容, 或在本文件内容基础上进行任何修改, 均属于侵权行为, 本公司保留追究法律责任的权利。