

Transfer or duplication of this document as well as the utilization or communication of its contents are prohibited unless authorized in writing by Degson. All rights reserved for patent, utility model or design registrations. 除专利等权利明确标注外，其他标注均归德松公司所有。未经许可，不得复制或传播本文件内容。德松公司保留所有权利。

| 未注公差/General tolerances (mm) | | | | | | | | | | | | 0.1/10 | |
|------------------------------|-------|-------|-------|-------|-------|-------|-------|-------|-------|-------|-------|--------|-------|
| 0 | >3 | >6 | >10 | >18 | >30 | >50 | >80 | >120 | >180 | >250 | >315 | | >400 |
| ~3 | ~6 | ~10 | ~18 | ~30 | ~50 | ~80 | ~120 | ~180 | ~250 | ~315 | ~400 | ~500 | >500 |
| ±0.12 | ±0.18 | ±0.22 | ±0.26 | ±0.31 | ±0.37 | ±0.57 | ±0.80 | ±0.93 | ±1.05 | ±1.15 | ±1.60 | ±2.20 | ±2.50 |

| UL 标准/UL Standard: | B | C | D |
|--|-----------------|--------|-------|
| 额定电压/电流/Rated Voltage(V)/Current(A) | 300/8 | / | 300/8 |
| IEC 标准/IEC Standard: | | | |
| 过压类别/Overvoltage Category/污染等级/Pollution Degree | III/3 | III/2 | II/2 |
| 额定电压/电流/Rated Voltage(V)/Current(A) | / | 250/12 | / |
| 额定脉冲电压(KV)/Rate Impulse Voltage(KV) | / | 4 | / |
| 线径范围(硬线和软线)/Wire Range(rigid and flexible)(AWG/mm ²) | 28~16 / 0.2~1.5 | | |
| 间距/Pitch(mm)/线数范围/Poles | 3.5/N=02~24P | | |
| 剥线长度/Stripping length(mm) | 9 | | |
| 使用温度范围/Operating temperature(°C) | -40~+105 | | |
| 符合RoHS环保要求/Conform to RoHS | Yes | | |

02-06P with clip point
07-24P without clip point

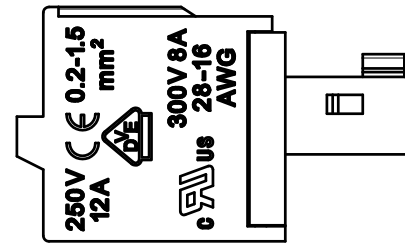
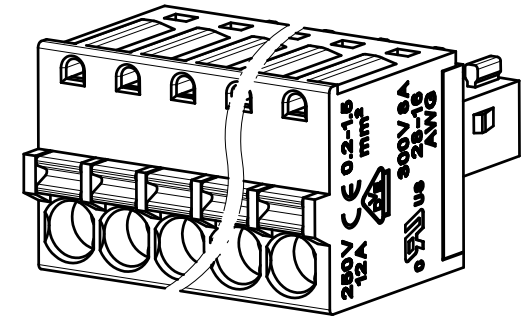
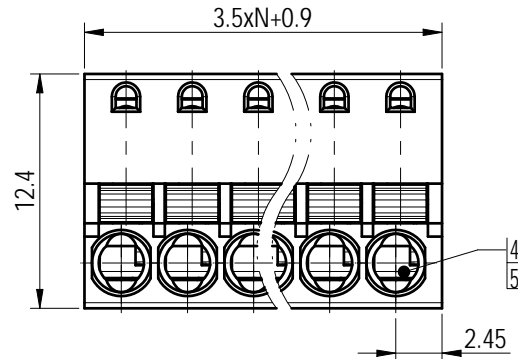
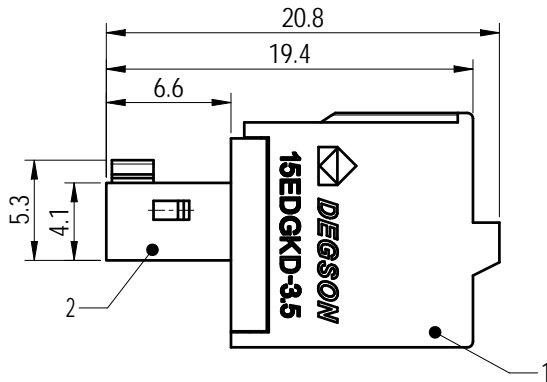
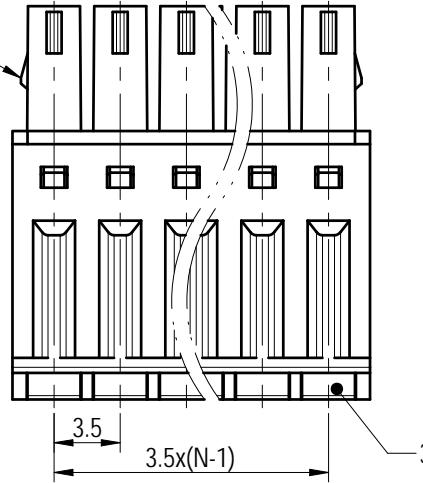

| ITEM | NAME OF PART | MATERIAL | NOTES |
|------|--------------|-----------------|-----------|
| 5 | Spring | Stainless steel | / |
| 4 | Clamp | Copper alloy | Sn Plated |
| 3 | Button | POM | UL94HB |
| 2 | Cover | PA66 | UL94V-0 |
| 1 | Housing | PA66 | UL94V-0 |

| | | | | | |
|-------------|------------------|---------------------------|-------|----------------|--|
| | | MATERIAL: | | SURFACE/COLOR: | |
| | | MAT NO./REV: - / 00 | | MAT STATUS: 批量 | |
| APPD: 兰春华 | 2024.05.22 | NAME | | | |
| CHKD: 龚耀志 | 2024.05.22 | 15EDGKD-3.5-XXP-1Y-00Z(H) | | | |
| DRFT: 方哲盛 | 2024.05.22 | | | | |
| DRAWING NO. | TYPE | DRAWING STATUS | SCALE | SHEET | |
| 200019524 | CUSTOMER DRAWING | 已发布 | 2.5:1 | 1/1 | |

| REV | ECN | DESCRIPTION | DRFT | DATE |
|-----|-----|--|------|------------|
| 01 | | Revise the drawing surface according to the object | 方哲盛 | 2024.05.22 |