

PCB LAYOUT

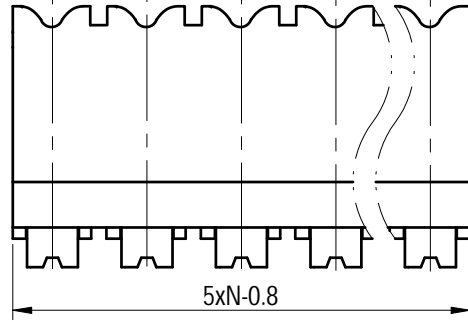

未注公差/General tolerances (mm)													0.1/10	
0	>3	>6	>10	>18	>30	>50	>80	>120	>180	>250	>315	>400		
~3	~6	~10	~18	~30	~50	~80	~120	~180	~250	~315	~400	~500	>500	
±0.12	±0.18	±0.22	±0.26	±0.31	±0.37	±0.57	±0.80	±0.93	±1.05	±1.15	±1.60	±2.20	±2.50	±2°

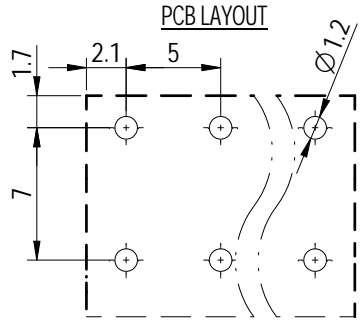
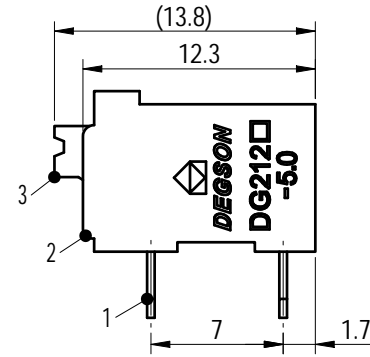
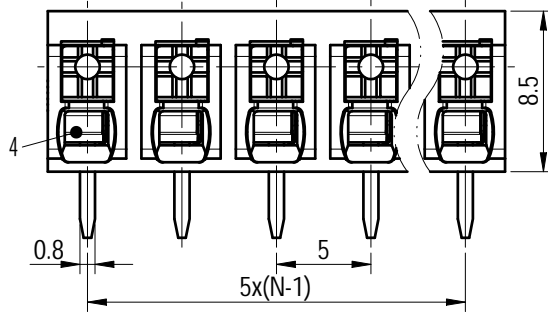
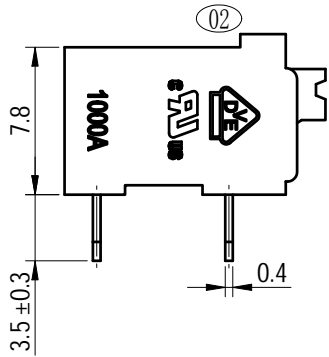
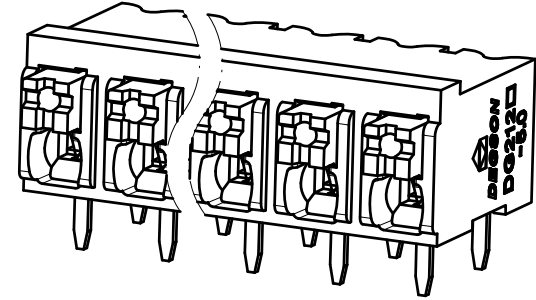

ITEM	NAME OF PART	MATERIAL	NOTES
4	Spring	Stainless steel	/
3	Button	PA66+GF	UL94V-0
2	Housing	Thermoplastic	UL94V-0
1	Pin header	Copper Alloy	Sn Plated

UL 标准/UL Standard:	B	C	D
额定电压/电流/Rated Voltage(V)/Current(A)	300/12	/	300/10
IEC 标准/IEC Standard:			
过压类别/Overvoltage Category/污染等级/Pollution Degree	III/3	III/2	II/2
额定电压/电流/Rated Voltage(V)/Current(A)	320/17.5	320/17.5	500/17.5
额定脉冲电压(KV)/Rate Impulse Voltage(KV)	4	4	4
线径范围(硬线和软线)/Wire Range(rigid and flexible)(AWG/mm²)	28~14 / 0.2~1.5		
间距/Pitch(mm)/线数范围/Poles	5.0/N=02~24P		
剥线长度/Stripping length(mm)	8~9		
使用温度范围/Operating temperature(°C)	-40~+130		
符合RoHS环保要求/Conform to RoHS	Yes		

<b>DEGSON</b>		MATERIAL:	SURFACE/COLOR:	
APPD: 兰春华	2023.07.13	MAT NO./REV:	/ 00 MAT STATUS: 批量	
CHKD: 张玉华	2023.07.13	NAME		
DRFT: 陈迪辉	2023.07.13	DG212R-THR-5.0-XXP-1Y-1000Z (H)		
DRAWING NO.	TYPE	DRAWING STATUS	SCALE	SHEET
200022169	CUSTOMER DRAWING	已发布	2.5:1	1/1

REV	ECN	DESCRIPTION	DRFT	DATE
02		IX Add VDE certification mark	陈迪辉	2023.07.13

Transfer or duplication of this document as well as the utilization or communication of its contents are prohibited unless explicit authorization is granted. Violations will be liable for compensation. All rights reserved for patent, utility model or design registrations. 除非得到明确授权,否则禁止复制或传播,否则侵权必究。本公司保留所有权利。侵权必究。